



GEL 6110 with connector option **ST** (right) and hybrid cable option **xx** (left)



GEL 6110 with hollow shaft option **U** and hybrid cable option **H1**

General

The PowerDRIVE GEL 6110 forms a compact positioning unit, consisting of a DC brushless motor, a novel magnetic multiturn absolute rotary encoder, a 32-bit microprocessor, a compact power amplifier, as well as an efficient spur gear. The positioning drive is available in short or long design. For each design, three spur gears from 1.4 Nm to 10 Nm nominal torque are available.

Active system protection against thermal overload and comprehensive system software allow load-dependent duty cycles well above 25%.

The robust stainless steel housing with its high protection class (IP67) permits numerous applications in various sectors of industry. Alternatively, a form-rigid aluminum housing with protection class IP67 is also available.

Features

- ▶ Spur gear with 1.4 Nm up to 10 Nm
- ▶ Stainless steel or aluminum housing, Viton-sealed
- ▶ Protection class IP 67
- ▶ Operating temperature -10°C to $+60^{\circ}\text{C}$
- ▶ DCBL motor
- ▶ Magnetic multiturn absolute rotary encoder
 - Accuracy $\pm 1.8^{\circ}$
 - 342 turns
- ▶ 32-bit microcontroller
- ▶ CANopen DS 402, PROFIBUS-DP V0/V1
- ▶ High output power

Advantages

- ▶ Either hybrid cable or plug outlet
- ▶ Onboard joystick for easy commissioning
- ▶ Monitoring of important system parameters ensures safe operation (overload protection)
- ▶ Operational immediately after power on due to absolute multiturn position detection
- ▶ Maintenance-free due to sealed-for-life lubrication

Fields of application

- ▶ Packaging machines
- ▶ Food and bottling plants
- ▶ Wood and plastic processing machinery
- ▶ Printing and book binding machinery
- ▶ Large production facilities

Description

Construction

The positioning drives in the PowerDRIVE GEL 6110 series are intelligent positioning units for pushing onto the end of a shaft or attachment to a shaft. Various accessories are available for mounting.

The concept of the positioning drive includes a force-fit and form-fit shaft connection so that the machine axle bears the weight of the positioning drive. A torque support (accessory) prevents the positioning drive turning with the shaft and compensates for any imbalance movements on the output axle. The shape and design of the torque support are application-specific.

The PowerDRIVE GEL 6110 provides torques of 1.4 Nm at 230 min⁻¹ up to 10 Nm at 40 min⁻¹ via a compact spur gear. It is operated with a supply voltage of 24 V DC and supports the fieldbus profiles CANopen DS402 and PROFIBUS-DP V0/V1.

A mechanical manual adjustment⁽¹⁾ is provided to operate the PowerDRIVE in case of malfunction during e.g. power failure.

The rotary selection switches for device ID and baud rate setting, as well as a USB service connector, are accessible on the back of the device. The positioning drive can also be operated in real-time without prior PLC programming in the set-up mode using a joystick.

The optional holding brake guarantees secure locking even in case of shock and vibration loads - especially on vertical feed axes.

Integrated absolute rotary encoder

A multiturn absolute rotary encoder on magnetic basis eliminates reference search routines following an emergency stop or a power failure. Due to the integrated absolute rotary encoder, the batteryless positioning drive detects its position immediately after the power is switched on and is immediately ready for use.

In the switched off state the output shaft can be moved ± 171 turns without losing the absolute position.

The absolute rotary encoder withstands high shock/ vibration loads.

Reliability

Important parameters such as motor power and device temperature are monitored and in this way the positioning drive is actively protected against overload. The following monitoring features ensure trouble-free operation:

- ▶ Soft starting and stopping via acceleration and deceleration ramps
- ▶ Undervoltage detection on the power supply
- ▶ Contouring error detection
- ▶ Temperature monitoring
- ▶ Overload protection for the motor and the power amplifier by I²t monitoring
- ▶ Sensor monitoring

System solution

In combination with the PowerDRIVE-Box GEL 6500, Lenord + Bauer offers a system solution for the PowerDRIVE GEL 6110. With the hybrid cable, the power supply and the desired interface profile for the positioning drives are configured via the PowerDRIVE-Box.

The hybrid cable is suitable for use in drag chains and permits easy connection.

PowerDRIVE-Connect

The hybrid cable PowerDRIVE-Connect is designed for flexible application in drag chains and reaches a permissible dynamic bending radius of ten times the cable diameter in a temperature range of -40 °C to +80 °C. The diameter of the cable is 9.5 mm. The hybrid cable is screened under the PUR outer sheath. The internal communication cores are fully insulated and multiply screened.

The positioning drive is available with hybrid cable and connector. PowerDRIVE and PowerDRIVE-Box can be quickly and easily connected with pre-assembled field attachable hybrid connection cables.

Mounting position

The PowerDRIVE GEL 6110 is mounted with the narrow side horizontally or vertically to the shaft. The drive shaft (fixed bearing) and the attachment point of the torque support (floating bearing) must be aligned to keep the mechanical stresses on all components as small as possible.

An assembly in transverse position with the wide side up is not allowed.

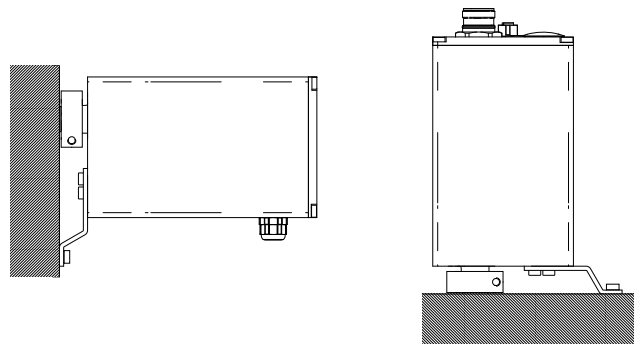

Permissible mounting positions: horizontal (left) or vertical (right)

⁽¹⁾ Use not recommended for PowerDRIVE GEL 6110 with holding brake (option)!

Technical data

Electrical data	
Nominal voltage, control system	24 V DC -5% / +20%
Nominal voltage, motor	24 V DC -5% / +20% (Attention: max. motor speed is voltage-dependent!)
Nominal current, control system	Max. 400 mA, internal protection, self-resetting
Nominal current, motor	5 A, maximum current 10 A, external protection necessary
Duty cycle (ED) (load-dependent)	ED = 25% at 100% load torque, short time operation S2 (base time 4 minutes: On = 1 minute, Off = 3 minutes) ED > 50% at 50% load torque, dependent on ambient parameters and application
Resolution	1000 increments per 360°
Accuracy	±1.8°
Detection range	342 turns
Positioning range	Unlimited
Interfaces	CANopen (DS-402) PROFIBUS-DP (V0/V1) Further interfaces using PowerDRIVE Box GEL 65xx
Insulation test in accordance with DIN EN 60439-1	500 V DC
EMC ⁽¹⁾	Electromagnetic immunity EN 61000-6-1 and -2 Electromagnetic emissions EN 61000-6-4
Mechanical data	
Nominal torque of output shaft (for variant M _N ⁽²⁾) 01 (housing EK/AK) 02 (housing EL/AL) 03 (housing EK/AK; for shaft option U reduced by 10%) 05 (housing EL/AL; for shaft option U reduced by 10%) 07 (housing EK/AK) 10 (housing EL/AL)	1.4 Nm at 230 min ⁻¹ 2 Nm at 230 min ⁻¹ 3.5 Nm at 100 min ⁻¹ 5 Nm at 100 min ⁻¹ 7 Nm at 40 min ⁻¹ 10 Nm at 40 min ⁻¹
Service life at nominal load (for nominal torque option) 1.4 Nm, 2 Nm, 3,5 Nm, 5 Nm 7 Nm, 10 Nm	3000 h 1000 h
Output shafts	Semi hollow shaft, solid shaft, external square, internal square, hollow shaft, customised shafts upon request
Max. shaft load (axial)	30 N
Max. shaft load (radial)	50 N
Housing material EK / EL housing AK / AL housing	Stainless steel 1.4301 Aluminum AlMgSi
Weight EK / EL housing AK / AL housing AK / AL housing with hollow shaft / bevel gears option U	3.0 kg / 3.5 kg 1.6 kg / 2.0 kg 3.0 kg / 3.4 kg
Protection class in accordance with DIN EN 60529	IP 67, shaft sealing ring made of Viton
Shock resistance as per DIN IEC 60068-2-27	150 m/s ² (15g)
Vibration resistance as per DIN IEC 60068-2-6	50 m/s ² (5g), 10 to 50 Hz
Ambient data	
Assured operating temperature range	0 °C to +60 °C
Operating temperature range	-10 °C to +60 °C
Storage temperature range	-20 °C to +85 °C
Max. relative humidity of air	95 %
Condensation	Not allowed (condensation protection on request)

(1) Only use screened cables

(2) Designations according to type code

Technical data, Product overview

Connections

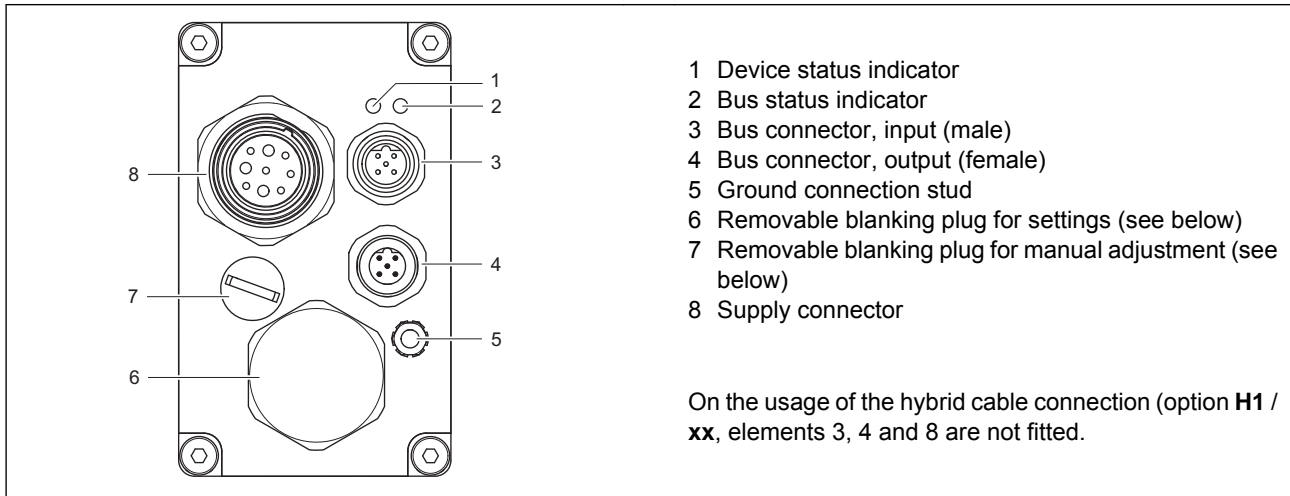

- 1 Device status indicator
- 2 Bus status indicator
- 3 Bus connector, input (male)
- 4 Bus connector, output (female)
- 5 Ground connection stud
- 6 Removable blanking plug for settings (see below)
- 7 Removable blanking plug for manual adjustment (see below)
- 8 Supply connector

On the usage of the hybrid cable connection (option **H1 / xx**, elements 3, 4 and 8 are not fitted).

Settings

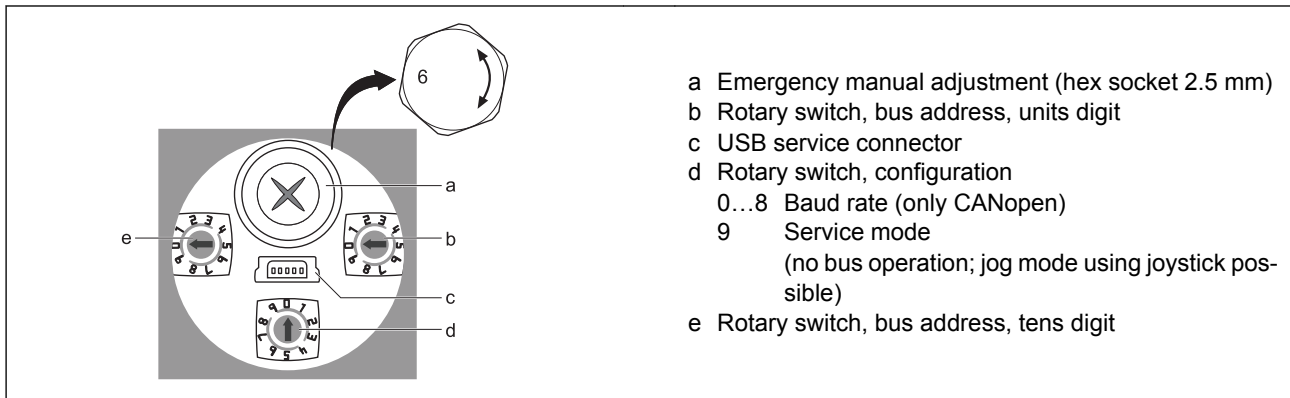

- a Emergency manual adjustment (hex socket 2.5 mm)
- b Rotary switch, bus address, units digit
- c USB service connector
- d Rotary switch, configuration
 - 0...8 Baud rate (only CANopen)
 - 9 Service mode (no bus operation; jog mode using joystick possible)
- e Rotary switch, bus address, tens digit

Manual adjustment (joystick)

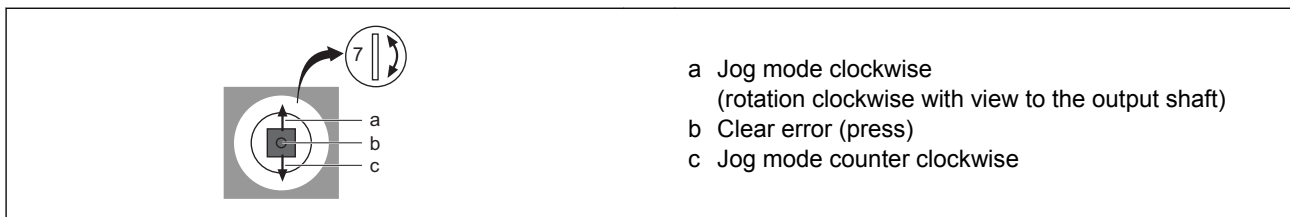

- a Jog mode clockwise (rotation clockwise with view to the output shaft)
- b Clear error (press)
- c Jog mode counter clockwise

Pin layout, Dimensional drawing

Pin layout – connector option ST

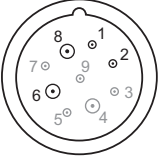
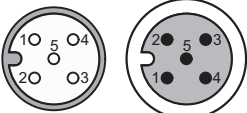
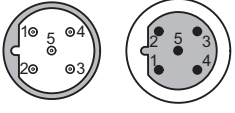
Supply connector		CANopen connector		PROFIBUS-DP connector	
M23  male contacts		M12 A-coded  IN OUT male female		M12 B-coded  IN OUT male female	
Pin		Pin	IN / OUT	Pin	IN OUT
1	+ 24 V DC control system	1	Cable screen	1	n.c. 5 V bus voltage
2	GND control system	2	n.c.	2	A-wire A-wire
6	+ 24 V DC motor	3	CAN_GND	3	n. c. GND bus
8	GND drive	4	CAN_H	4	B-wire B-wire
GND lines internally connected		5	CAN_L	5	Cable screen Cable screen

Pin layout – hybrid cable (PowerDRIVE-Connect)⁽¹⁾

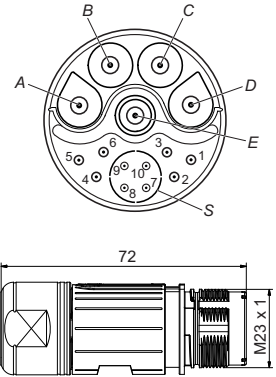
with M23 connector / option H1		open cable end / option xx		Assignment
coupling with pins (male contacts)	Pin	Core colour	Cross-section [mm ²]	
	A	red	0,5	+24 V control system
	B	black	0,5	GND control system
	C	black	1,5	GND motor
	D	red	1,5	+24 V motor
	E	–	–	Cable screen
	7	yellow	0,25	CAN_H
	8	black	0,14	CAN GND
	9	green	0,25	CAN_L
	S	–	–	CAN screen

Conneting accessories ⁽²⁾

Description	Part number
Mating connector PROFIBUS-DP, M12, coded B, input (female)	FS 3016
Mating connector PROFIBUS-DP, M12, coded B, ouput (male)	FS 3017
Termination resistor PROFIBUS-DP, M12, B-coded (male)	FS 3041
Mating connector CANopen, M12, coded B, input (female)	FS 3020
Mating connector CANopen, M12, coded A, ouput (male)	FS 3021
Termination resistor CANopen, M12, A-coded (male)	FS 3040
Mating connector supply voltage, M 23 female	FS 3038

(1) Field attachable connection cables are available, see "Technical information 61BZK".

(2) Further accessories: fieldbus cables, couplings etc. upon request

Dimensional drawing

Dimensional drawing – PowerDRIVE GEL 6110 with semi hollow shaft

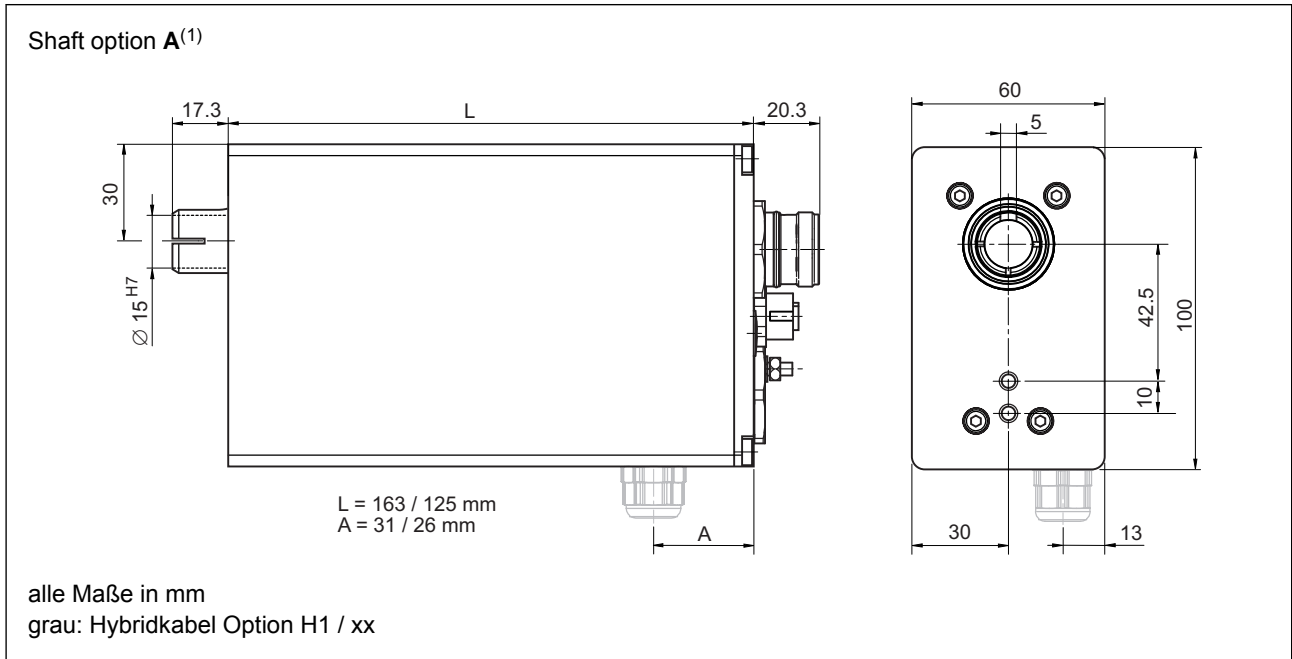

Mounting accessories⁽²⁾

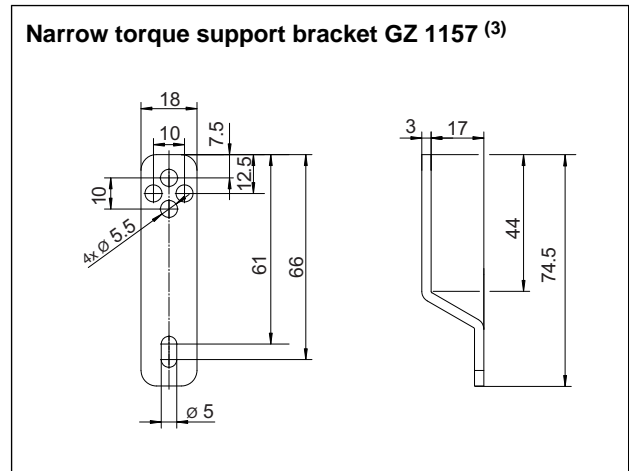
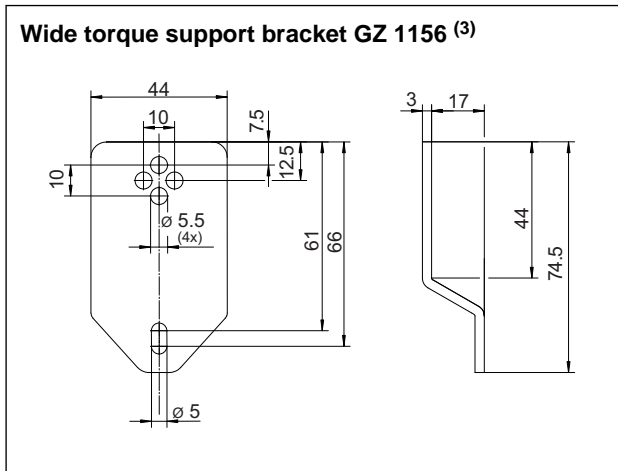

Clamping ring

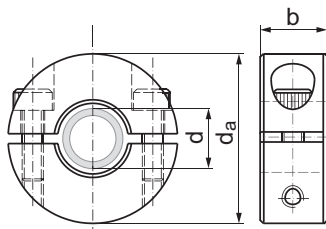

	MZ 13711	MZ 13701	MZ 13651	MZ 13761
Shaftd [mm] (option)	10/11 (F/E)	12/13 (D/C)	14/15 (B/A)	16/17/18/19/20 (P/N/Q/R/O)
da [mm]	39,4	41,2	46,4	48,1
b [mm]	13	13	15	15
Screw DIN 912	M5	M5	M6	M6

(1) Dimensions for shaft options B to R correspond to the specified dimensions.

(2) Further mounting material made from stainless steel 1.4301: centring pins, flange plates etc. upon request.

(3) Fitted on site using dowel screw (item № VS 3304) or clamping bush set (upon request)

Dimensional drawing

Dimensional drawing – PowerDRIVE GEL 6110 with hollow shaft and bevel gears

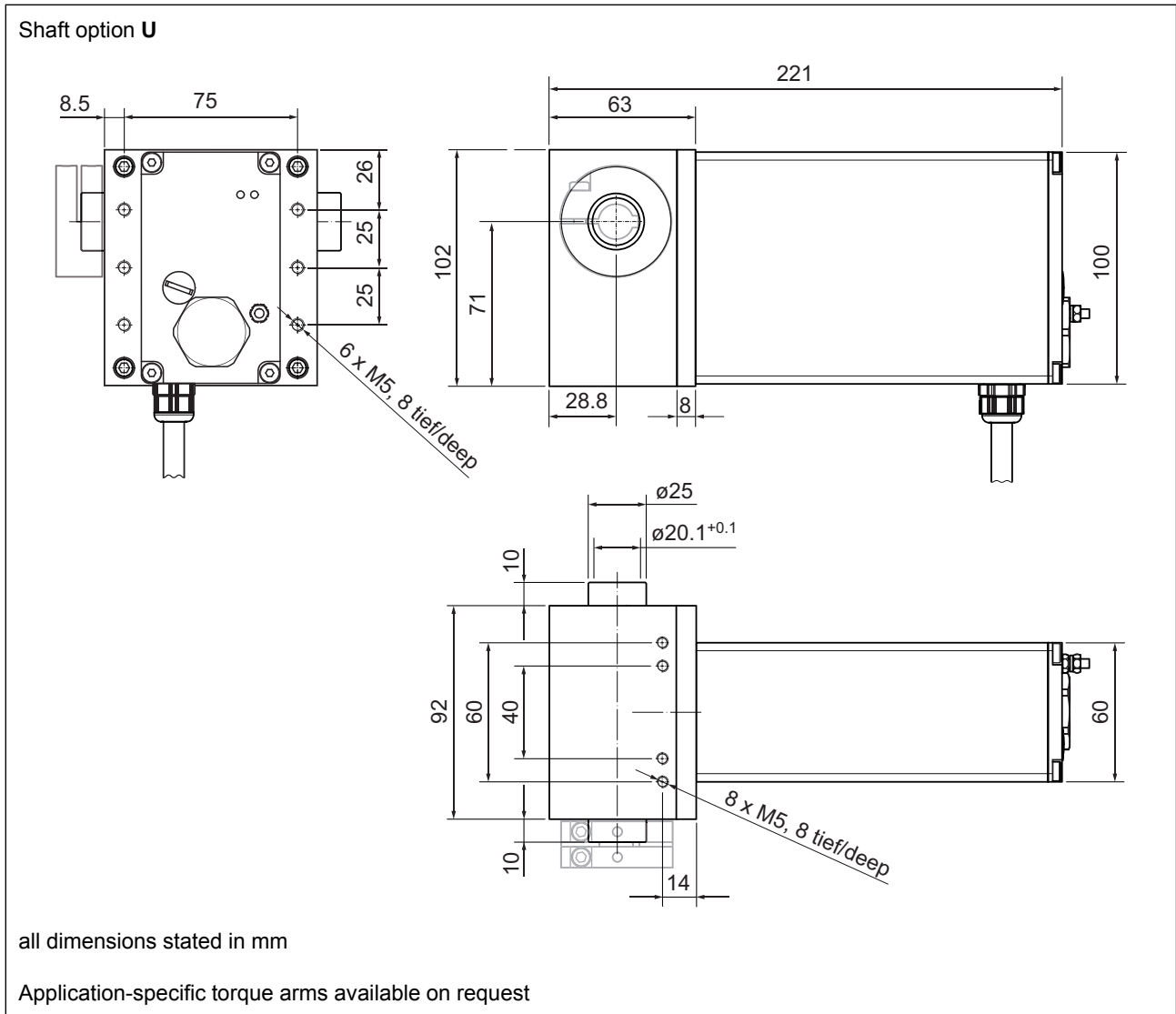

Mounting accessories

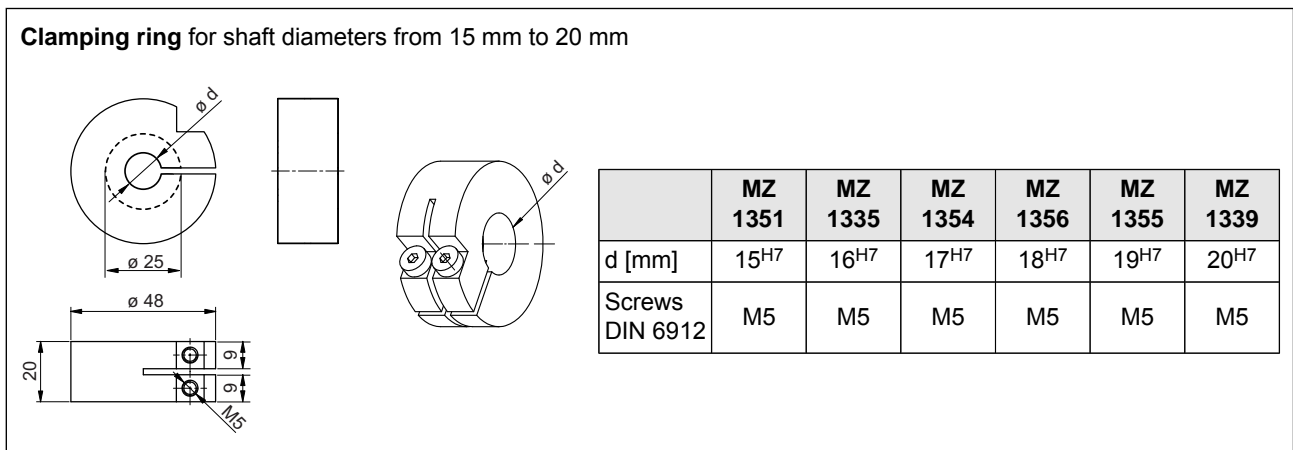

Type code GEL 6110

Type code GEL 6110

6110	Interfaces	
	CO	CANopen DS 402
	DP	PROFIBUS-DP V0/V1
	--	Other bus systems upon request or alternative PowerDRIVE-Box/hybrid cable
	Nominal torque (M_N)	
	01	1.4 Nm at 230 min ⁻¹ (for housing option AK/EK)
	02	2 Nm at 230 min ⁻¹ (for housing option AL/EL)
	03	3 Nm at 100 min ⁻¹ (for housing option AK/EK)
	05	5 Nm at 100 min ⁻¹ (for housing option AL/EL)
	07	7 Nm at 40 min ⁻¹ (for housing option AK/EK)
10	10 Nm at 40 min ⁻¹ (for housing option AL/EL)	
Shaft in mm		
A	15 H7 semi hollow shaft	
B	14 H7 semi hollow shaft	
C	13 H7 semi hollow shaft	
D	12 H7 semi hollow shaft	
E	11 H7 semi hollow shaft	
F	10 H7 semi hollow shaft	
G	10 H7 hollow shaft, flush (only internal form fit)	
K	10 h7 solid shaft	
L	10 external square	
M	10 internal square	
N	17 H7 semi hollow shaft	
O	20 H7 semi hollow shaft	
P	16 H7 semi hollow shaft	
Q	18 H7 semi hollow shaft	
R	19 H7 semi hollow shaft	
U	20 mm hollow shaft and bevel gears, only for housing option: ⁽¹⁾ - AL with nominal torque option 05 - AK with nominal torque option 01 or 03 - Customised shafts (upon request) ⁽²⁾	
Housing		
AL	Aluminum AlMgSi, L = 163 mm; option: holding brake	
AK	Aluminum AlMgSi, L = 125 mm; holding brake not possible; reduced nominal operation	
EL	Stainless steel 1.4301, L = 163 mm; option: holding brake	
EK	Stainless steel 1.4301, L = 125 mm; holding brake not possible; reduced nominal operation	
--	Customised housing (upon request) ⁽²⁾	
Hybrid cable / connector		
ST	Connector (standard: M12 fieldbus, M23 supply) ⁽³⁾	
H1	Hybrid cable (length 30 cm) with M23 connector (coupling with pin contacts) ⁽⁴⁾	
xx	Hybrid cable with open cable end, length in m (xx = 01...20; standard: 3 m)	
Equipment		
0	Standard (with standard components)	
1	UL/CSA hybrid cable for H1 / xx versions	
Option		
A	None (standard)	
B	Holding brake	
IP class		
3	Protection class IP 67 (with shaft sealing ring and protection against humidity)	

(1) For hollow shaft option **U** nominal torque is reduced by 10%.

(2) customer-specific, as per approval drawing

(3) mating connector M23 not included in scope of supply, see accessories

(4) field attachable connection cables available, see "Technical information 61BZK".

Subject to technical modifications and typographical errors.
 The latest version can be downloaded at www.lenord.com.

